

PRODUCT SUBMITTAL

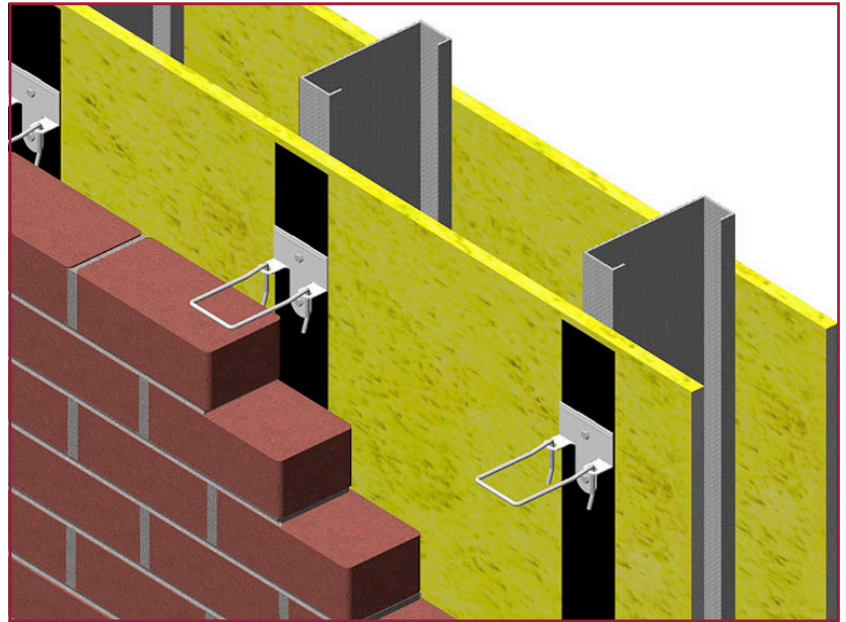

2401 RJ-711 Adjustable Veneer Anchor

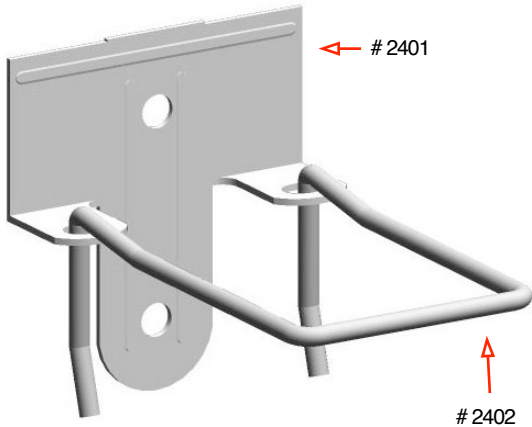

MATERIAL CONFORMANCE

ASTM A82 / A82M - (Cold drawn steel wire)
Tensile Strength - 80,000 psi
Yield Point - 70,000 psi

ACI / ASCE 530 - (Building code requirements for masonry structures)

SHEET METAL - (Carbon Steel) **ASTM A1008 / A1008M**

Mill Galvanized / Zinc Coating: **ASTM A641 / A641M (0.10 Oz per sq ft)**

Hot Dip Galvanized after fabrication / Zinc Coating
ASTM A153 / A153M-B2 (1.50 oz per sq ft)

Stainless Steel **ASTM 580 / ASTM 580M Type 304** (Type 316 available on special order)

Steel Products (flats):

Mill Galvanized & Hot Dip,
59.2% Post-Consumer
8.8% Post Industrial / Pre -
Consumer

Stainless Steel,
60% Post Consumer
V O C Content - 0%

WIRE Recycled Content:

Mill Galvanized & Hot Dip,
85% Post-Consumer
13% Post Industrial / Pre -
Consumer

Stainless Steel,
60% Post Consumer
V O C Content - 0%

SIZES / FINISHES

2401 RJ711:

14 gauge 12 gauge

Must be 3/4" more than insulation

Insulation:

0" 1" 1-1/2" 2" 2-1/2"

3" 3-1/2" 4"

2402 Hook: 3/16"Ø

3-1/4" 4-1/4" 5-1/4" Other _____

FINISH:

Mill Galvanized
 Hot Dip Galvanized
 Stainless Steel



Corporate Office: 400 Roundtree Rd Charlotte, NC 28217
TEL: (800) 849-6722 FAX: (704) 525-3761

Mailing Address: P.O. Box 240988 Charlotte, NC 28224



www.wirebond.com

Memphis Plant: 2365 Harbor Ave. Memphis, TN 38113
TEL: (800) 441-8359 FAX: (901) 775-9449

Mailing Address: P.O. Box 13124 Memphis, TN 38113